

# Specifications

Drawing No.	UKY1C-H1-14053-00[37] 1/10
Issued Date.	Jan,17,2014

**TO: KED USA**

---

**Note: In case of specification change, KYOCERA Part Number also will be changed.**

Product Name	Quartz Crystal
Product Model	CX2016DB
Frequency	27000kHz
Customer Part Number	-
Customer Specification Number	-
KYOCERA Part Number	CX2016DB27000H0FLFC1
Remarks	Pb-Free, RoHS Compliant, MSL 1

## Customer Acceptance

Accept Signature	Approved Date	
	Department	
	Person in charge	

Seller

**KYOCERA Corporation**

6 Takeda Tobadono-cho, Fushimi-ku, Kyoto

612-8501 Japan

TEL. No. 075-604-3500

FAX. No. 075-604-3501

Manufacturer

**KYOCERA Crystal Device Corporation**

5850, Higashine-Koh, Higashine-Shi, Yamagata

999-3701 Japan

TEL. No. 0237-43-5611

FAX. No. 0237-43-5615

Design Department	Quality Assurance	Approved by	Checked by	Issued by
KYOCERA Crystal Device Corporation Crystal Units Engineering Section Crystal Units Division	A. Kikuchi	Y.Takahashi	T. Nitoube	Y. Kikuchi

## Revision History

Rev.No.	Description of revise	Date	Approved by	Checked by	Issued by
1	First Edition	Jan,17,2014	Y.Takahashi	T. Nitoube	Y. Kikuchi

### 1. APPLICATION

This specification sheet is applied to quartz crystal "CX2016DB"

### 2. KYOCERA PART NUMBER

CX2016DB27000H0FLFC1

### 3. RATINGS

Items	SYMB.	Rating	Unit	Remarks
Operating Temperature	Topr	-30~+85	°C	
Storage Temperature range	Tstg	-40~+85	°C	

### 4. CHARACTERISTICS

#### ELECTRICAL CHARACTERISTICS

Items	Electrical Specification					Test Condition	Remarks
	SYMB.	Min	Typ.	Max	Unit		
Mode of Vibration		Fundamental					
Nominal Frequency	F0		27		MHz		
Nominal Temperature	T <sub>NOM</sub>		+30		°C		
Load Capacitance	CL		12.0		pF	Saunders(S&A) Network Analyzer 250B	
Frequency Tolerance	df/F	-10.0		+10.0	PPM	+30±3°C	
Frequency Temperature Characteristics	df/F	-10.0		+10.0		-30~+85°C	
Frequency Aging Rate		-1.0		+1.0		1 year	+30±3°C
Equivalent Series Resistance	ESR			80	Ω		
Drive Level	Pd	0.01		100	μW		
Insulation Resistance	IR	500			MΩ	100V(DC)	

**5. APPEARANCES, PHYSICAL DIMENSION**  
**OUTLINE DIMENSION (not to scale)**

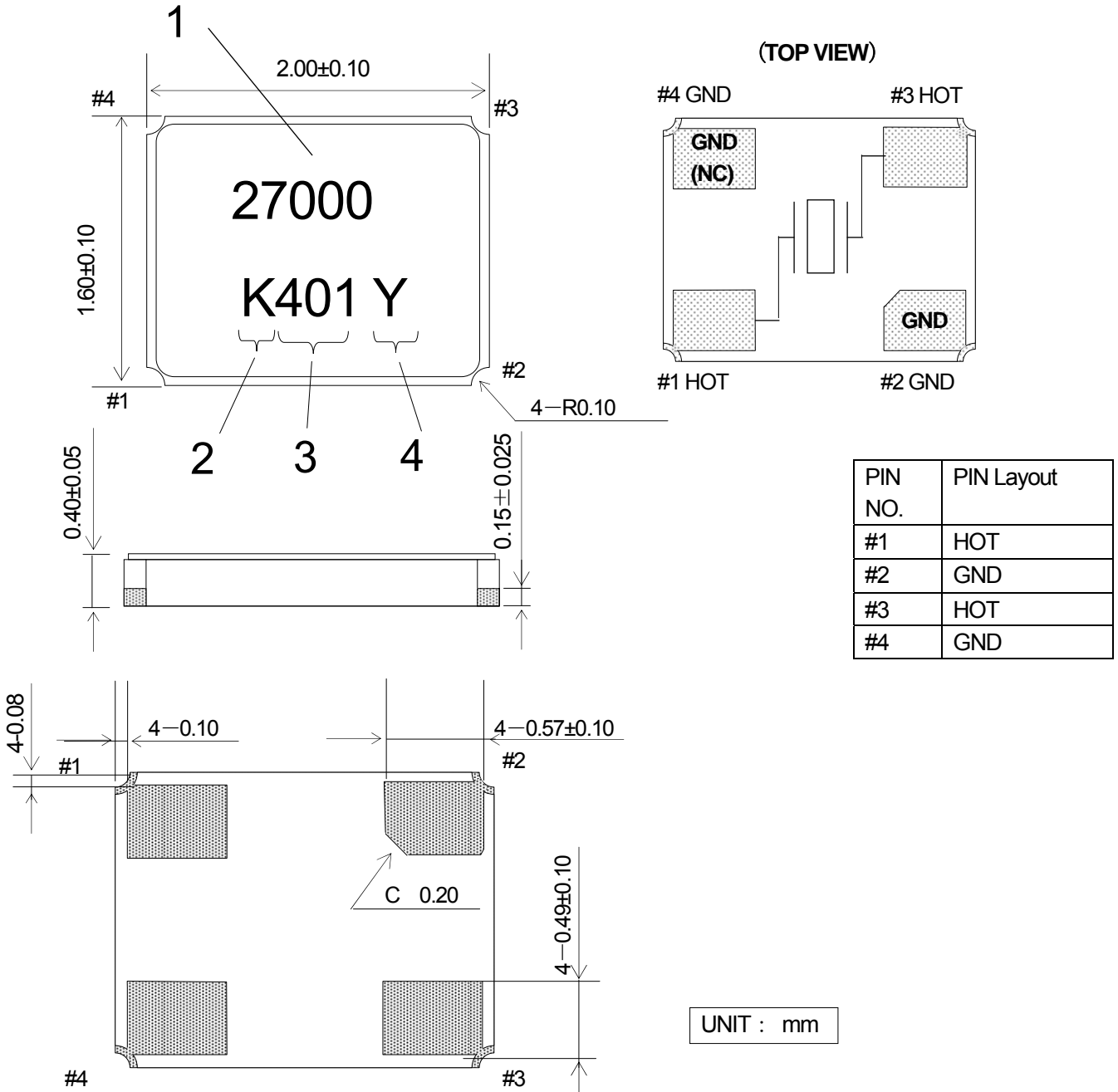

**MARKING**

- 1 Nominal Frequency Move the number of maximum indication beams of the frequency to five digits, and omit less than kHz.
- 2 Identification [K] mark is surely 1Pin direction.
- 3 Date Code Year · · LAST 1 DIGIT of YEAR AND WEEK  
(Ex)Jan,01, 2014 → 401
- 4 Manufacturing Location  
 Y··Yamagata  
 Z··Shiga Yohkaichi  
 T··Thailand  
 F··Philippines

※The font of marking is reference.

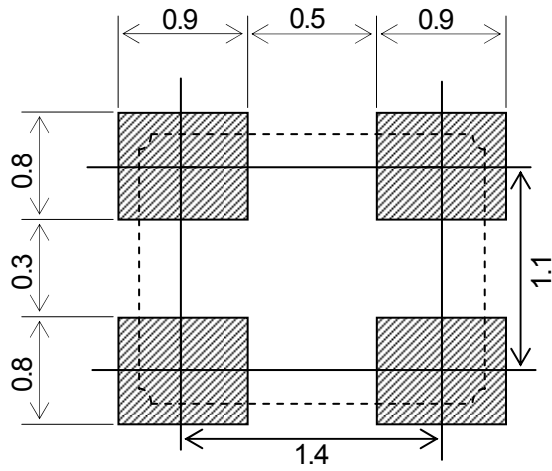
**6. RECOMMENDED LAND PATTERN (not to scale)**

UNIT : mm

## 7. TAPING & REEL

### 7-1. Dimensions

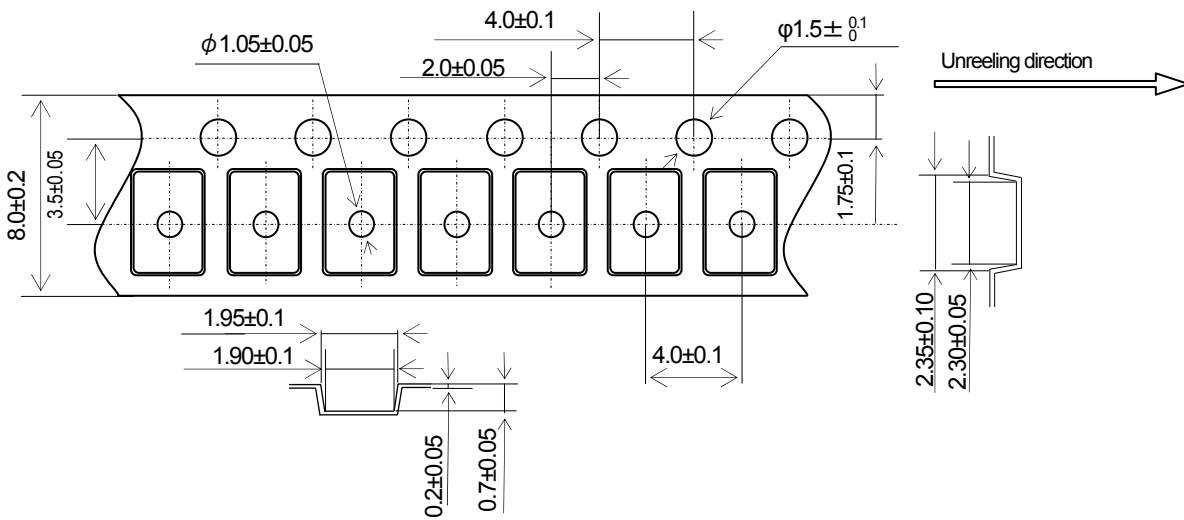

### 7-2. Leader and trailer tape

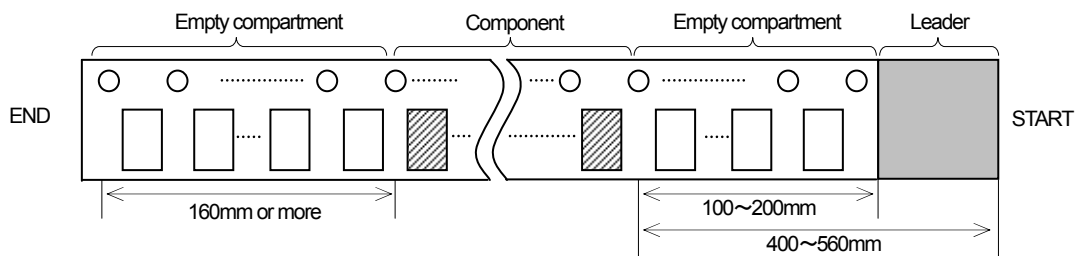

### 7-3. Direction (The direction shall be seen from the top cover tape side)

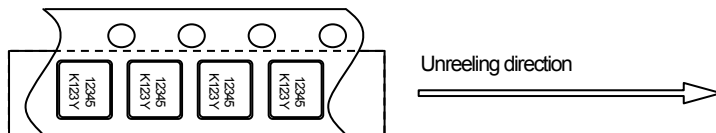

### 7-4. Specification

1. Material of the carrier tape shall be polystyrene or A-PET (ESD).
2. Material of the seal tape shall be polyester (ESD).
3. The seal tape shall not cover the sprocket holes. And not protrude from the carrier tape.
4. Tensile strength of the tape: 10N or more.
5. The R of the corner without designation is 0.2RMAX.
6. The alignment between centers of the cavity and sprocket hole shall be 0.05mm or less.
7. Cumulative pitch tolerance of "P<sub>0</sub>" shall be ±0.2mm at 10 pitches.
8. Suppose that it unifies as shown in the above-mentioned figure to the directivity of printing in an embossing tape.
9. Peeling force of the seal tape: 0.1 to 1.0N.
10. The component can fall headlong naturally from taping in the environment, such dry conditions, when this components were transferred to, cover was removed and the component was moved upside down.

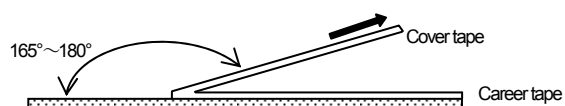

7-5.Reel Specification

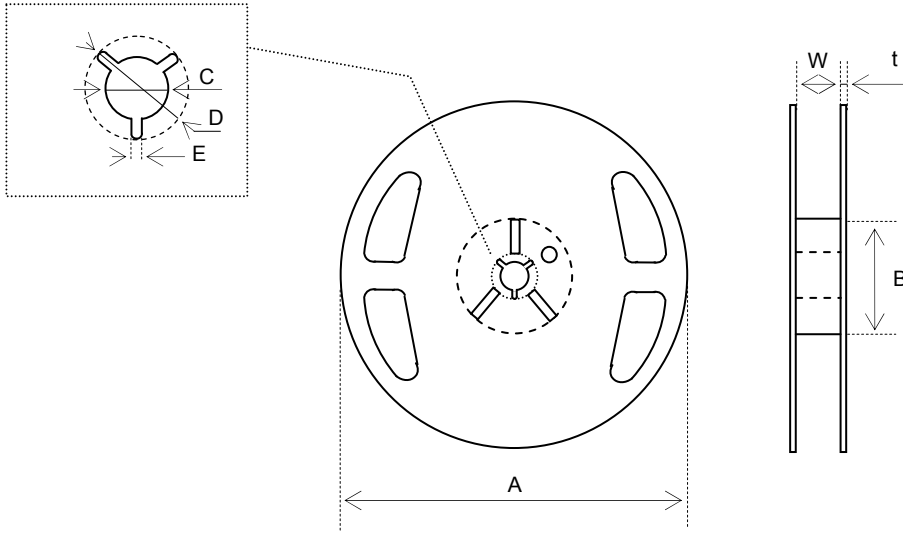

In the case of  $\phi 180$  Reel (3,000 pcs max, every 1,000 pcs)

Symbol	A	B	C	D
Dimension	$\phi 180 +0/-3$	$\phi 60 +1/-0$	$\phi 13 \pm 0.2$	$\phi 21 \pm 0.8$
Symbol	E	W	t	
Dimension	$2.0 \pm 0.5$	$9 \pm 1$	$2.0 \pm 0.5$	

(Unit : mm)

In the case of  $\phi 330$  Reel (12,000 pcs max, every 1,000 pcs)

Symbol	A	B	C	D
Dimension	$\phi 330 \pm 2.0$	$\phi 100 \pm 1.0$	$\phi 13 \pm 0.2$	$\phi 21 \pm 0.8$
Symbol	E	W	t	
Dimension	$2.0 \pm 0.5$	$9.5 \pm 0.5$	$2.2 \pm 0.1$	

(Unit : mm)

### 8.Environmental requirements

After following test, frequency shall not change more than  $\pm 10 \times 10^{-6}$   
 And CI,  $\pm 20\%$  or  $5\Omega$  of large value.

- |     |                         |   |
|-----|-------------------------|---|
| 8.1 | Resistance to Shock     | Test condition<br>Natural dropped from height 100cm onto hard wood board in 3 times   |
| 8.2 | Resistance to Vibration | Test condition<br>frequency : 10 - 55 - 10 Hz<br>Amplitude : 1.5mm<br>Cycle time : 15 minutes<br>Direction : X,Y,Z (3direction),2 h each.   |
| 8.3 | Resistance to Heat      | Test condition<br>The quartz crystal unit shall be stored at a temperature of $+85 \pm 2^\circ\text{C}$ for 500 h.<br>Then it shall be subjected to standard atmospheric conditions for 1 h ,after whichi measurement shall be made.  |
| 8.4 | Resistance to Cold      | Test condition<br>The quartz crystal unit shall be stored at a temperature of $-40 \pm 2^\circ\text{C}$ for 500 h.<br>Then it shall be subjected to standard atmospheric conditions for 1 h ,after whichi measurement shall be made.  |
| 8.5 | Thermal Shock           | Test condition<br>The quartz crystal unit shall be subjected to 500 succesive change of temperature cycles , each as shown in table below, Then it shall be subjected to standard atmospheric conditions for 1h, after which measurements shall be made.<br>Cycle : $-40 \pm 2^\circ\text{C}$ (30min.) to $+25 \pm 2^\circ\text{C}$ (5min.)<br>to $+85 \pm 2^\circ\text{C}$ (30min.) to $+25 \pm 2^\circ\text{C}$ (5min.) |



8.6 Resistance to Moisture

Test condition

The quartz crystal unit shall be stored at a temperature of  $+60 \pm 2^\circ\text{C}$  with relative humidity of 90% to 95% for 240 h. Then it shall be subjected to standard atmospheric conditions for 1h, after which measurements shall be made

8.7 Soldering condition

1.) Material of solder

Kind ... lead free solder paste

Melting point ...  $+220 \pm 5^\circ\text{C}$

2.) Reflow temp.profile

	Temp [ $^\circ\text{C}$ ]	Time[sec]
Preheating	+150 to +180	150 (typ.)
Peak	$+260 \pm 5$	10 (max.)
Total	—	300 (max.)

Frequency shift :  $\pm 2\text{ppm}$

3.) Hand Soldering + $350^\circ\text{C}$  3 sec MAX

4.) Reflow Times 2 times

Reflow temp.profile

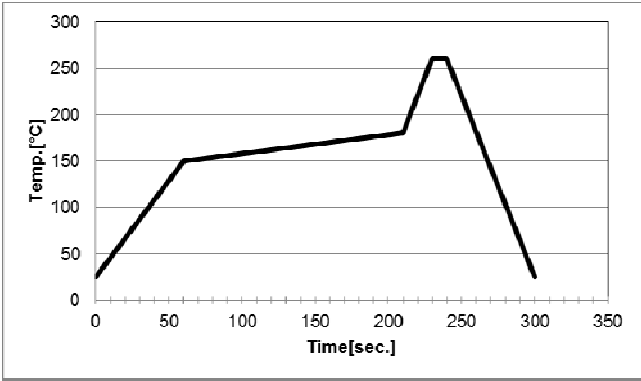

8.8 Intensity for bending in circuit board

Solder this product in center of the circuit board of  $40\text{mm} \times 100\text{mm}$ , and add the deflection of 3mm as the bottom figure.

Test board :  $t = 1.6\text{mm}$

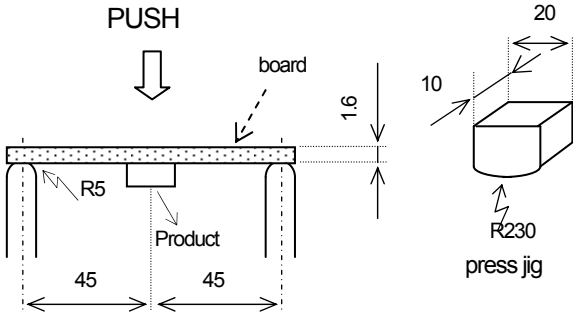

UNIT : mm

## 9. Cautions for use

### (1) Soldering in mounting

In case of Solder paste and conductive glue contact product lid or product side face exception for product terminal it's possible to influence product characteristics.

Please be careful above contents.

### (2) Automatic mounting machine use

Please use after affirmation that select the mounting machine model with a shock small if possible in the case of use of an automatic mounting machine, and it does not have breakage. There is a risk of a crystal oscillating child's breakage occurring and not functioning normally by too much shock etc.

### (3) Conformity of a circuit

In case of use of an oscillation circuit, please insert in a crystal oscillating child in series resistance 5 times as many as the standard value of equivalent in-series resistance, and confirm oscillating. Please remove resistance which inserted after the notes above-mentioned examination in the crystal oscillating child in series, and use it.

## 10. Storage conditions

Storage at prolonged high temperature or low temperature and the storage by high humidity cause degradation of frequency accuracy, and degradation of soldering nature. Storage is performed at the temperature of +18 to +30°C, and the humidity of 20 to 70 % in the state of packing, and a term is 6 months.

## 11. Manufacturing location

Kyocera Crystal Device Corporation

Kyocera Crystal Device Corporation Shiga Yohkaichi Plant

Kyocera Crystal Device (Thailand) Co., Ltd

Kyocera Crystal Device Philippines, Inc.

## 12. Quality Assurance

Kyocera Crystal Device Quality Assurance Division

## 13. Quality guarantee

When the failure by the responsibility of our company occurs clearly after delivery within 1 year, a substitute article etc. is appropriated gratuitously and this is guaranteed. However, when passing 1 year after delivery, there is a case where I am allowed to consider as onerous repair after both consultation.

## 14. Others

When any questions and opinions are in the written matter of these delivery specifications, I will ask connection of you from the company issue day within 45 days. In a connection no case, a written matter is consented to it and employed within a term.